

Economics Data Analysis Device - Research on Enhancing the Efficiency of Economic Forecasting and Decision Making

Xianing Tang ^{1, a}, Junjie Peng ^{2, b}, Xiuyuan Zhang ^{1, c}, Yuhui Liu ^{1, d}

¹ Gannan Normal University, school of economics and management, Ganzhou, 341000, China

² Gannan Normal University, school of physical education major, Ganzhou, 341000, China

^a 1151290925@qq.com; ^b 1179227041@qq.com; ^c 3241430068@qq.com; ^d 949358872@qq.com

ABSTRACT

This paper discusses an economics data analysis device, belonging to the technical field of data analysis devices, including a base plate and a universal wheel located at the bottom of the base plate, the top of the base plate is connected with a vertical column, the top of the vertical column is slidingly connected with a lifting column, the top of the lifting column is connected with an outer frame plate, the inner side wall of the outer frame plate is mounted with a display, the top of the base plate is mounted with an electric motor, the output end of the electric motor is connected with a screw rod, the screw rod of the motor is connected to a threaded rod, the outer side wall of the threaded rod is threadedly connected to a sleeve block, the outer side wall of the sleeve block is connected to a connecting block, and the outer side wall of the connecting block is slidingly connected to the outer side wall of the vertical column. The economics data analysis device, through the operation of the motor, the threaded rod is then rotated, and then through the use of the sleeve block and the connecting block, the lifting column is then moved, causing the height of the outer frame plate to change, so as to achieve the effect of facilitating the adjustment of the height of the display, and thus facilitating the observation and analysis of the data graph displayed on the display.

KEYWORDS

Economics Device; Data Analysis; Economic Database

1. INTRODUCTION

With the rapid development of economic globalisation and information technology, economics data analysis plays an increasingly important role in economic decision-making, policy formulation and academic research. The construction and maintenance of economic databases provide key information such as macro data, industry data, and corporate records for analyses, but how to effectively use these data to extract valuable insights is a major challenge nowadays. Existing data analysis devices, such as the data analysis device for enterprise disclosed in CN218037807U, although providing functions of data presentation and protection to a certain extent, still have some limitations in practical application. For example, these devices may lack the ability to analyse complex economic models or have deficiencies in user interaction and data visualisation.

The present study aims to address the prior art problem that it may not be easy to adjust the height of the display, which may not facilitate the observation and analysis of the data by a person who is far away from the display, which may result in errors in the results of the data analysis, as well as the problem that it may not be easy to adjust the position of the display, and to design a device for analysing data in economics.

The device not only provides more secure data display and storage functions, but also improves the efficiency and accuracy of data analysis through advanced statistical analysis methods and a user-friendly interface. Our goal is to develop a data analysis tool that can meet the needs of modern economics research and practice.

2. SYSTEM DESIGN

Architecture: Describe the overall architecture of this economics data analysis device, including data acquisition module, height adjustment module, direction control module, data pre-processing module, data intelligent analysis module and visual decision support system.

The specific structure is shown in the following figure:

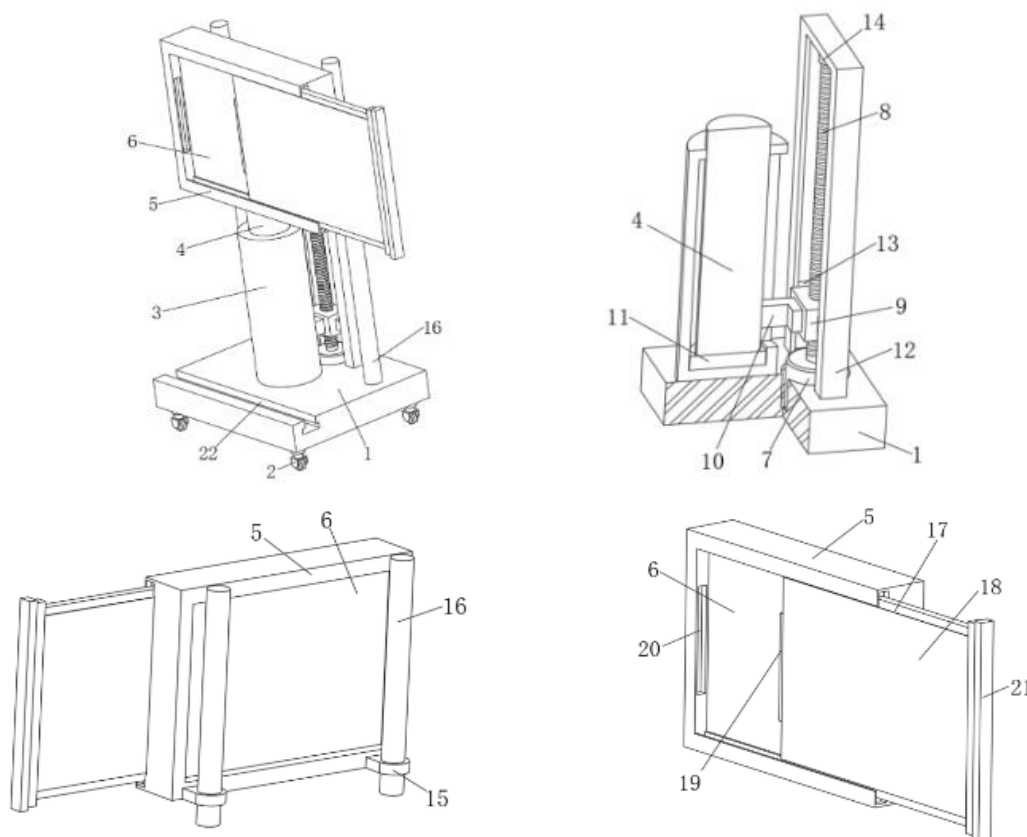

Figure 1. Schematic structure of the device

Where the name of each part is: 1- base plate, 2- universal wheel, 3- vertical column, 4- lifting column, 5- outer frame plate, 6- display, 7- motor, 8- threaded rod, 9- sleeve block, 10- connecting block, 11- sliding disc, 12- U-shaped plate, 13- slider, 14- bearing, the 15- Ear plate, 16- Positioning rod, 17- Bar plate, 18- Guard plate, 19- First magnet, 20- Second magnet, 21- convex plate, 22- convex groove

Key technologies: Introduces the specific technologies adopted, mainly display height adjustment technology, device connection technology, device stabilisation technology and glass surface protection technology.

Data Integration: Analyses how to achieve height control, data storage, data analysis and ensure the efficient and stable operation of the device through the use of height control systems, data resources, data storage systems, data monitoring and prediction, data analysis and other technical means.

3. APPLICATION BENEFIT ANALYSIS

Enhance the efficiency and quality of data analysis: By precisely adjusting the height of the monitor, users are able to review and analyse data from the most comfortable viewing angle, reducing errors caused by poor posture or poor viewing angle, and improving the accuracy and efficiency of data analysis. Especially during long periods of centralised data processing, good viewing conditions are essential to maintain analyst focus and reduce errors.

Facilitates teamwork and communication: The flexibility of the device is not limited to individual use, but is equally beneficial for teamwork. The unit can be quickly moved to a meeting room or collaborative area when analysis results need to be shared or discussed in a group, and the quick adjustment of the monitor height can be adapted to the needs of different speakers or audience members, facilitating the unobstructed exchange of information.

Adaptation to diverse work environments: The unit is particularly adaptable in changing office environments. Whether it's an open-plan workspace, a personal office or an ad-hoc project team, the unit quickly adjusts to the environment and user preferences, creating a personalised work interface that enhances job satisfaction and productivity.

4. DISCUSSION

4.1. Advantages

Highly specialised design: the device is custom-developed for the characteristics of economics, and the built-in professional models and algorithms can more accurately handle macroeconomic indicators and industry data, improving the depth and breadth of analysis and helping users gain quick insight into economic trends.

Efficient Data Processing Capability: The combination of integrated high-performance hardware and optimised software algorithms greatly improves data processing speed, making instant analysis of large-scale datasets possible and providing faster response time for decision-making.

User-friendly interactive experience: The customised professional interface for economics reduces the learning cost of users, enhances the intuitiveness and convenience of operation, and improves work efficiency.

Enhanced data security: The use of advanced encryption technology and permission management strategy effectively protects the privacy and security of economic data, especially when dealing with sensitive information, and enhances user trust.

4.2. Limitations

Cost: Highly specialised and customised equipment is usually accompanied by high R&D and production costs, which may limit its popularity in certain resource-limited organisations.

Iterative technology updates: data analytics technology is changing rapidly, and while the current design is more advanced, the emergence of new technologies in the future may require frequent hardware and software upgrades, increasing maintenance costs.

Adaptability challenges: Although the device is designed for economics, the broad field of economics and the specific needs of different users may vary, making it difficult to fully meet the specific requirements of all market segments.

5. FUTURE OUTLOOK

Artificial Intelligence Integration: with the development of AI technology, future economics data analysis devices will be more intelligent, capable of learning economic patterns on their own, providing predictive analyses and intelligent decision-making suggestions.

Cloud and Edge Computing Integration: Using cloud computing resources to process large-scale data, combined with edge computing to reduce latency and provide more immediate data analysis services, while ensuring flexibility and security of data processing.

Modular and scalable design: Designing a more modular and scalable system, allowing users to add or remove functional modules as needed, enhancing the flexibility and applicability of the device.

Interdisciplinary integration: Combine data analysis techniques from other disciplines, such as sociology and environmental sciences, to form a multi-dimensional economic analysis capability to respond to more complex economic phenomena and social issues.

Continuous optimisation of user experience: Through continuous collection of user feedback, we will continuously optimise the user interface and interaction design, so as to make the device more suitable for users' needs and improve the overall user experience.

6. SUMMARY

In summary, this study details an innovative economics data analysis device that achieves convenient adjustment of the height of the monitor through the synergistic work of its well-designed mechanical structure-including components such as the base plate, universal wheels, vertical columns, lifting columns, outer frame plates, motors, threaded rods, bushing blocks, and connecting blocks. This height-adaptive design not only solves the limitations of traditional fixed displays in economic data analysis scenarios, but also significantly improves the working comfort and efficiency of data analysts. Through the motor-driven precision adjustment system, users can easily adjust the monitor to the optimal viewing position according to their own needs, so as to more intuitively and accurately analyse and interpret complex economic data charts and graphs, and reduce misinterpretation caused by visual fatigue or discomfort.

The device significantly improves the ease and accuracy of data observation and facilitates more effective teamwork, especially in environments that require prolonged data monitoring and multi-dimensional analyses. Its flexible mobility and user-friendly design further adapts to the diverse needs of modern office spaces, providing advanced and efficient data analysis hardware support for economics research institutes, financial institutions, and educational institutions.

With the continuous advancement of AI, IoT and other technologies, the economics data analysis device is expected to further integrate intelligent adjustment functions, such as adjusting the height by voice command or remote control, or even automatically matching the best viewing angle based on the user's biometrics, in order to achieve a more intelligent and personalised data analysis experience. In addition, the modular design of the device leaves room for future technological upgrades and functional extensions, ensuring that it can continue to meet the increasingly complex needs of economics data analysis and promote the integration of data analysis technology and practice.

REFERENCES

- [1] Liu Lanting, Li Xuezheng. Research on the improvement of data analysis ability of economics students in the era of digital economy [J]. *China Management Informatisation*, 2023, 26(21):71-74.
- [2] Liu S. Application of economic mathematics in financial and economic analysis [J]. *Industrial Innovation Research*, 2022(07):106-108.

- [3] LIU Zhen, ZHANG Lirong. Political economy analysis of data capital formation and its characteristics [J]. Learning and Exploration, 2023(09):84-92.